

# TITANTAG™ Secure

Frequency	UHF
Protocol	ISO18000-6-C EPC C1G2
Region	EU
Dimensions (mm)	W95 H25 T3.1
Silicon chip	Alien Higgs3
Memory (bits)	TOTAL 800  EPC up to 480  User up to 512
Metal friendly	Both on/off metal
Reads up to meters	4.0 (On metal)  6.0 (Off metal)
Operating temperature	-45<>85°C
Storage temperature	-45<>150°C
IP class	IP68
Year of release	2007
Product code	952531E

UHF C1G2 (EU)	Silicon chips	W*H*T (mm)	Read (up to meters)	
			On metal	Off metal
Nail <sup>1/2</sup>	Alien Higgs3	13*7*2.1	0.2	0.2
Nail	Alien Higgs3	15*10*2.1	0.2	0.3
Inch TN	Alien Higgs3	26*10*2.1	0.7	0.5
Inch	Alien Higgs3	26*10*3.1	1.0	0.6
Inch SQ	Alien Higgs3	26*26*3.1	1.5	1.0
Inch SQ HT	Alien Higgs3	26*26*2.5	2.5	n/a
Tray NM	Impinj Monza4	35*15*3.1	n/a	1.0
Smallest	Alien Higgs3	39*10*3.1	2.5	1.0
Smallest AC	Alien Higgs3	39*10*3.1	2.5	0.5
Smallest MAG	Alien Higgs3	39*10*4.8	1.5	n/a
Tray E	Alien Higgs3	40*13*4.1	3.0	2.0
Smallest NM	Alien Higgs3	45*10*3.1	n/a	3.5
Spiral	Alien Higgs3	45*44*1.4	n/a	1.0
Strip	Alien Higgs3	60*6*3.1	2.0	0.5
Laundry	Alien Higgs3	68*9 *0.4	n/a	2.5
General TN	Alien Higgs3	75*16*2.1	2.5	2.0
General	Alien Higgs3	75*16*3.1	3.5	2.0
General AC	Alien Higgs3	75*16*3.1	3.5	2.0
Basic	Alien Higgs3	92*16*3.1	3.5	1.0
Basic MAG	Alien Higgs3	92*16*5.2	3.5	n/a
Basic L	Alien Higgs3	110*20*3.1	6.5	3.0
Pallet	Alien Higgs3	94*11*1.4	n/a	5.0
<b>Secure</b>	<b>Alien Higgs3</b>	<b>95*25*3.1</b>	<b>4.0</b>	<b>6.0</b>
Secure HT	Alien Higgs3	95*25*2.5	5.0	n/a
Blade	Alien Higgs3	139*6*4.0	6.0	5.0
Fastener	Alien Higgs3	148*18*3.1	6.0	8.0
Fastener MAG	Alien Higgs3	148*18*7.1	5.0	n/a
Fastener TK	Alien Higgs3	148*18*4.1	12.0	11.0
4KB5M	Fujitsu 803A	163*30*4.1	2.5	2.0

### [1] Secure Feature



### [2] Secure Dimensions (mm)

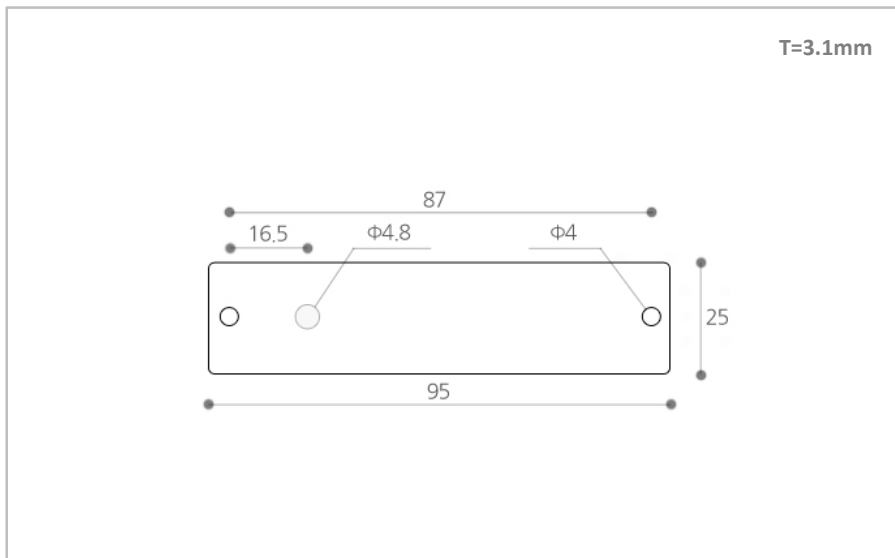

### [3] Key materials and processes

#### Silicon chip Alien Higgs3

- Read sensitivity of -20dBm – Best performing among UHF Gen 2 RFID chips
- Total 800bits memory – EPC 96bits (extensible to 480bits), User 512bits, TID 64 bits, Access& Kill password each 32bits and Lock password 64bits
- Most widely adopted chip for metal mounting UHF RFID tags
- Rfcamp has adopted Alien Higgs3 since year of 2008.

[www.alientechnology.com/wp-content/uploads/ALC-360%20Higgs3%202014-12-21.pdf](http://www.alientechnology.com/wp-content/uploads/ALC-360%20Higgs3%202014-12-21.pdf)

#### Antenna PCB FR4, Copper etched, Gold plated

- FR4 (Fire retardant 4, composed of woven fiberglass cloth with an epoxy resin binder) – Most stable and widely applied antenna materials in recent 30 years worldwide, with highest durability and consistent electrical property
- Copper etched antenna has much higher accuracy with lower tolerance than aluminum etched antenna and conductive ink printed antenna, which makes tag performance more consistent with lower read range variance.
- Gold is plated on chip bonded area of copper etched antenna, in order to enhance chip adhesion on antenna as well as electrical interconnection with antenna.

#### Packaging Double layer PCBs, laminated under high temperature and pressure

- Tag antenna has convoluted structure of two or three layers with copper ground plane, so tag is composed of double layer PCBs, tightly combined and laminated under high pressure and temperature of 200 °C for >2 hours.
- Many tag makers copy TITANTAG™ in appearance, but they can not copy tags' durability and read consistency.
- Surface of PCBs is coated with TOYO (black) PSR, best of kind which can protect it against electrical stress and water ingress.

#### Chip bonding Wire bonded, aluminum or gold

- Unlike other tag makers using flip chip bonding or chip soldering, Rfcamp has adopted wire bonding technology since year of 2004.
- Wire bonding, though most complicated and expensive chip bonding method, is most stable in electrical interconnection and most durable in mechanical and temperature stresses. It, with highest precision, is also best fit for working on complicated antenna patterns of double layer PCBs.

## [4] Secure Performance

• Performance table ([www.satcomresources.com/ERP-EIRP-Converter](http://www.satcomresources.com/ERP-EIRP-Converter))

Up to meters*	On metal	Off metal
2W ERP**	4.0	6.0
2W EIRP***	3.0	3.5

\* Measured at anechoic chamber, national lab. ([www.iot.nipa.kr](http://www.iot.nipa.kr)), South Korea

\*\* Measured by Alien Reader 9900+ ([www.alientechnology.com](http://www.alientechnology.com))

\*\*\* Measured by ATID Handheld AT880 ([www.atid1.com](http://www.atid1.com))

• Comparison with neighboring tags

MHz	860	865	870	875	880	885	890	895	900							
Secure	-	-	1.00	-	1.75	-	1.50	-	1.00	0.25	1.75	3.50	4.75			
Basic	-	0.50	1.25	3.00	4.25	5.50	7.00	8.00	9.25	10.25						
Blade	-	2.00	-	3.25	-	4.00	-	4.25	-	3.50	-	2.50	-	1.00	0.50	1.50

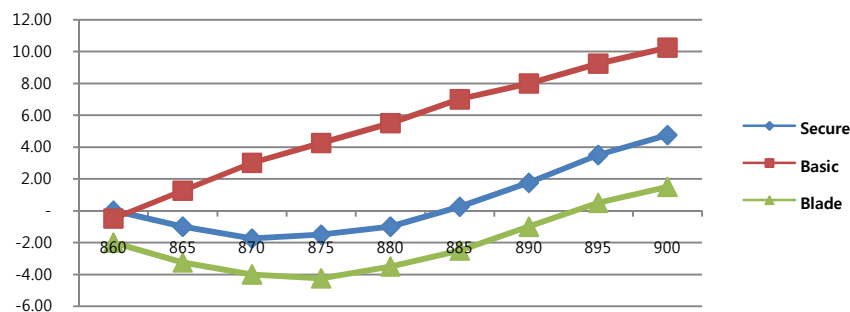

• **SECURE** reads up to 4.0 meters on metal, 30% longer than BASIC, but 25% shorter than BLADE. Though not best performing among similar size tags, its performance is most stable and consistent, as its slow and gentle slope of sensitivity curve shows.

• Its read performance varies upon tag location, orientation, direction, RF environments, etc.. Unlike other TITAN tags, its read performance is still same, even when space or backing adhesive between tag and metal surface gets thicker.

• Comparison: on vs. off metal

MHz	860	865	870	875	880	885	890	895	900									
On metal	-	-	1.00	-	1.75	-	1.50	-	1.00	0.25	1.75	3.50	4.75					
Off metal	-	5.50	-	5.00	-	4.50	-	3.75	-	3.00	-	2.25	-	1.50	-	0.75	-	0.25

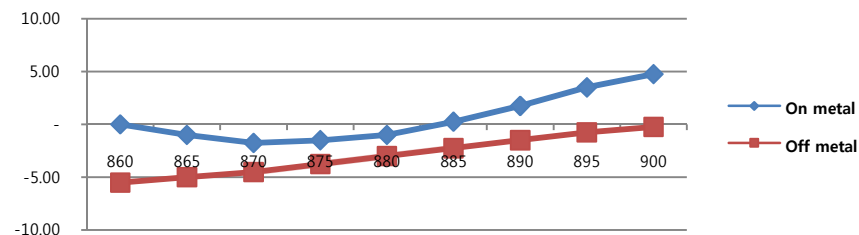

• **SECURE** reads longer by 30% or more off metal (or on non metal surface). It can be applied for BOTH metal and off metal application.

• Comparison: with metal bolt in vs. without it in

MHz	860	865	870	875	880	885	890	895	900					
w/o bolt	-	-	1.00	-	1.75	-	1.50	-	1.00	0.25	1.75	3.50	4.75	
w/t bolt	-	0.25	-	1.00	-	1.50	-	1.25	-	0.50	1.00	2.50	4.00	5.25

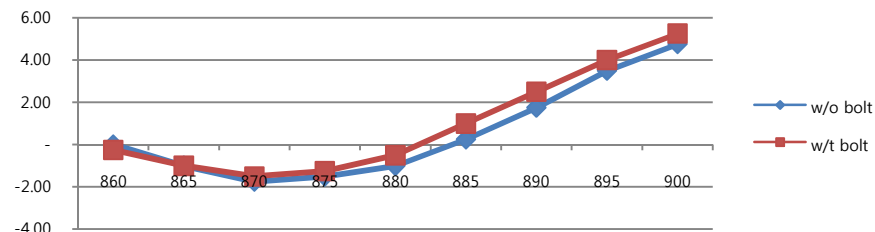

• **SECURE** reads same, regardless of whether it is fastened with metal bolt in two holes (located on center of both ends) or not. Stainless steel M3 bolt with round head is best fit for SECURE.

\*dBm : Minimum power tag needs in order to respond to RFID reader.

## [5] Secure Durability

### • Temperature stress

Test methods	Descriptions	Pass/Fail
150 °C, 6hrs	Stored in convection oven at 150C, 6hrs	Pass
-45<>85 °C, 50 cycles	Stored in temperature shock chamber for 50 cycles – One cycle includes 30 min. at-45C, 30 min, transition, 30min. at 85C and 30min. transition.	Pass
85 °C/85%, 24hrs	Stored in humidity chamber at 85C/85%RH for 24 hours	Pass
Boiling water, 6 hrs	Immersed in boiling water for 6 hours	Pass

### • Ingression [www.dsmt.com/resources/ip-rating-chart](http://www.dsmt.com/resources/ip-rating-chart)

IP Class	IP68	1.5 meter deep immersion, 1hr

### • Mechanical stress

Test methods	Descriptions	Pass/Fail
Iron ball fall test	Free fall of 1kg iron ball from 1.5meters height on any side of tag - 50 times	Pass
Vibration	IEC60068-2-6/64	Pass
Drop& topple	IEC60068-2-31	Pass
Shock (acceleration)	IEC60068-2-22	Pass
Pressure	50 Bar on any side of tag, 50 times	Pass

### • Chemical stress

Chemicals	Descriptions	Pass/Fail
Alkali	NaOH (10%, pH13)   Immersed 24 hrs.	Pass
Acid	Sulfuric acid (10%, pH2)   Immersed 24 hrs.	Pass
Petroleum	Gasoline, Diesel, Kerosene, lubricating oil   Immersed 24 hrs.	Pass
Alcohol	Methanol, Ethanol   Immersed 24 hrs.	Pass
Surfactant	Solvent for metal tool oils   Immersed 24 hrs.	Pass
Salt water	IEC60068-2-11	Pass

### • Electrical stress

ESD	IEC61000-4-2 (LEVEL4 – 8KV)	PASS
-----	-----------------------------	------

### • Radiation stress (N/A)

Gamma ray	kGy	
-----------	-----	--

ISO 11137-1:2012 Radiation/Gamma Ray method

### • Autoclave stress (N/A)

Autoclave conditions	Sterilization processes	
----------------------	-------------------------	--

ISO 17665-1:2006 Moist Heat/Steam Sterilization method

## [6] Secure Options

### • Chip encoding service

- Encodes EPC memory sector only\*.
- Encodes tags with 4 multiple digits - from 16 bits (4 digits decimal or hex or ASCII) up to 480 bits (120 digits decimal or hex or ASCII) - upon customers' request.
- Unless requested by customer, all tags are encoded with 24 digits decimal (Date 8 digits + Serial 16 digits), before shipped to customers. For example, code 201508140000000000001278 tells that tag was 1278<sup>th</sup> encoded on August 14, 2015.
- Tag code can be permanently locked with password of 8 digits decimal or hex, upon customer's request.

\* For special encoding service (e.g. TID to EPC or user memory encoding), please ask RFcamp.

### • Label & printing service

- Provides fast and reasonably priced custom label service with printing variable data, barcode and logo.
- Label material is water proof and "hard to tear off" polysynthetic.



### • Laser engraving & direct printing service

- With CO2 laser, tag surface is precisely and permanently etched into variable data, barcode and logo with black and yellow contrast.
- With silk screen printing or pad printing method, tag surface is permanently printed with various colored logo or text.



### • Backing adhesive

- Unless requested otherwise, RFcamp recommends and applies 3M468MP or 3M9472LE (Aka. 3M300LSE) double sided adhesive tapes for general applications. For harsh environments, RFcamp recommends 3M VHB tapes.
- For stronger adhesion, RFcamp suggests glue solutions such as Cemedine's Super X or Loctite's double compound epoxies.
- For special solution, please ask RFcamp.

### • Fasteners & brackets

- For some small TITANTAGs, metal fastener may adversely affect tag read performance, so please ask RFcamp for suitable solution.
- Upon customer's request, RFcamp develops metal based brackets for special applications, with optimal tag performance.



### • Encapsulations

- For special environment requiring enhanced chemical durability, RFcamp applies special coating materials over tag.
- Upon customer's request, RFcamp develops injection molded ruggedized case or rubber (polyurethane or silicone) based encapsulation.

